

Development of a General-purpose Analytical Tool for Evaluating Dynamic Characteristics of Thermal Energy Systems

Yutaka Watanabe¹ Toru Takahashi¹

¹Energy Engineering Research Laboratory, Central Research Institute of Electric Power Industry (CRIEPI), Japan, {yutaka, toru-tak}@criepi.or.jp

Abstract

The Central Research Institute of Electric Power Industry (CRIEPI) in Japan has developed an original tool for analyzing the dynamics of a wide range of thermal energy systems using Modelica. This tool was originally developed to analyze thermal power generation systems to evaluate the dynamic characteristics of a new and an existing thermal power generation systems and has been validated against several sets of operational data so far. As a next step, the tool was extended to calculate the thermophysical properties of not only water/steam and air/gas but also various refrigerants implementing the ExternalMedia library to model a customer-side equipment such as a heat pump system (Fig.1). Consequently, various and complex energy systems can now be analyzed with this tool.

As a case study to test the new adding part, a dynamic modeling of a hot-water supply system with CO₂ as the refrigerant at CRIEPI was carried out. The target test facility comprises a compressor, gas coolers, an electro-motion expansion valve, and evaporators (Fig.2). A simplified dynamic model was constructed with this tool (Fig.3). The validity of the tool was assessed via comparison with experimental data measured from a hot-water supply system with CO₂ refrigerant. The model accuracy of some elements of the system needs further improvement, though sufficiently accurate results for constructing a dynamic model were obtained.

Keywords: Modelica, energy system, heat pump

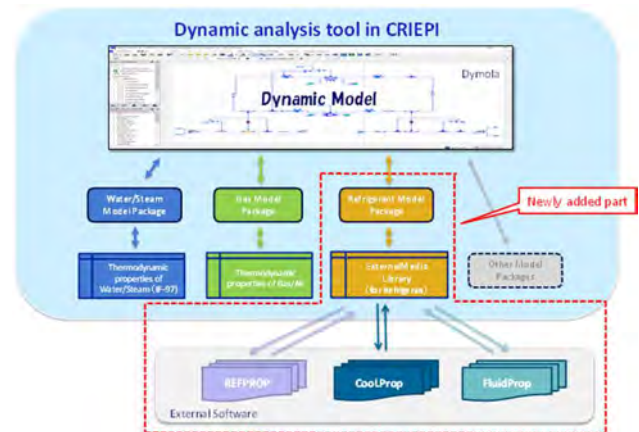

Figure 1. Schematic of the developed tool.

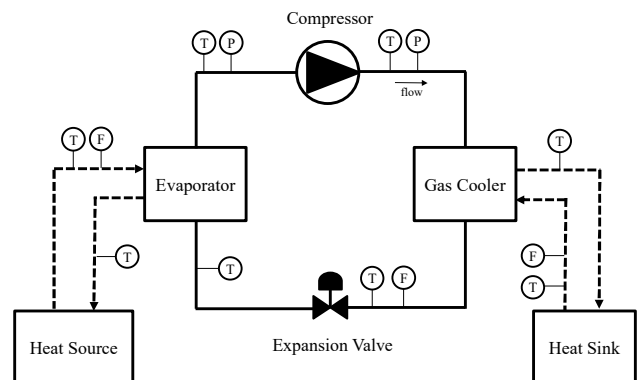

Figure 2. Schematic of the CO₂ heat-pump loop.

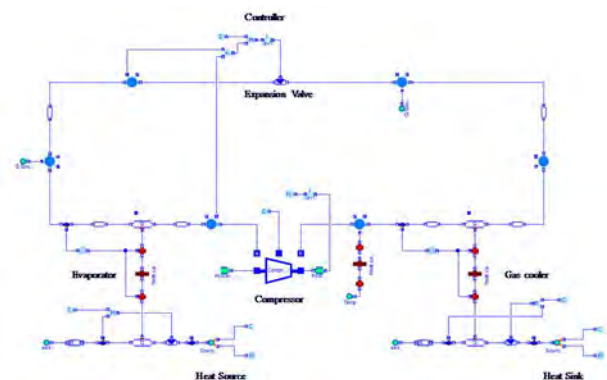

Figure 3. Dynamic model of CO₂ heat-pump-loop facility using CRIEPI's tool.